

Montaj Talimatları - Still FCU Kurt Ağzı

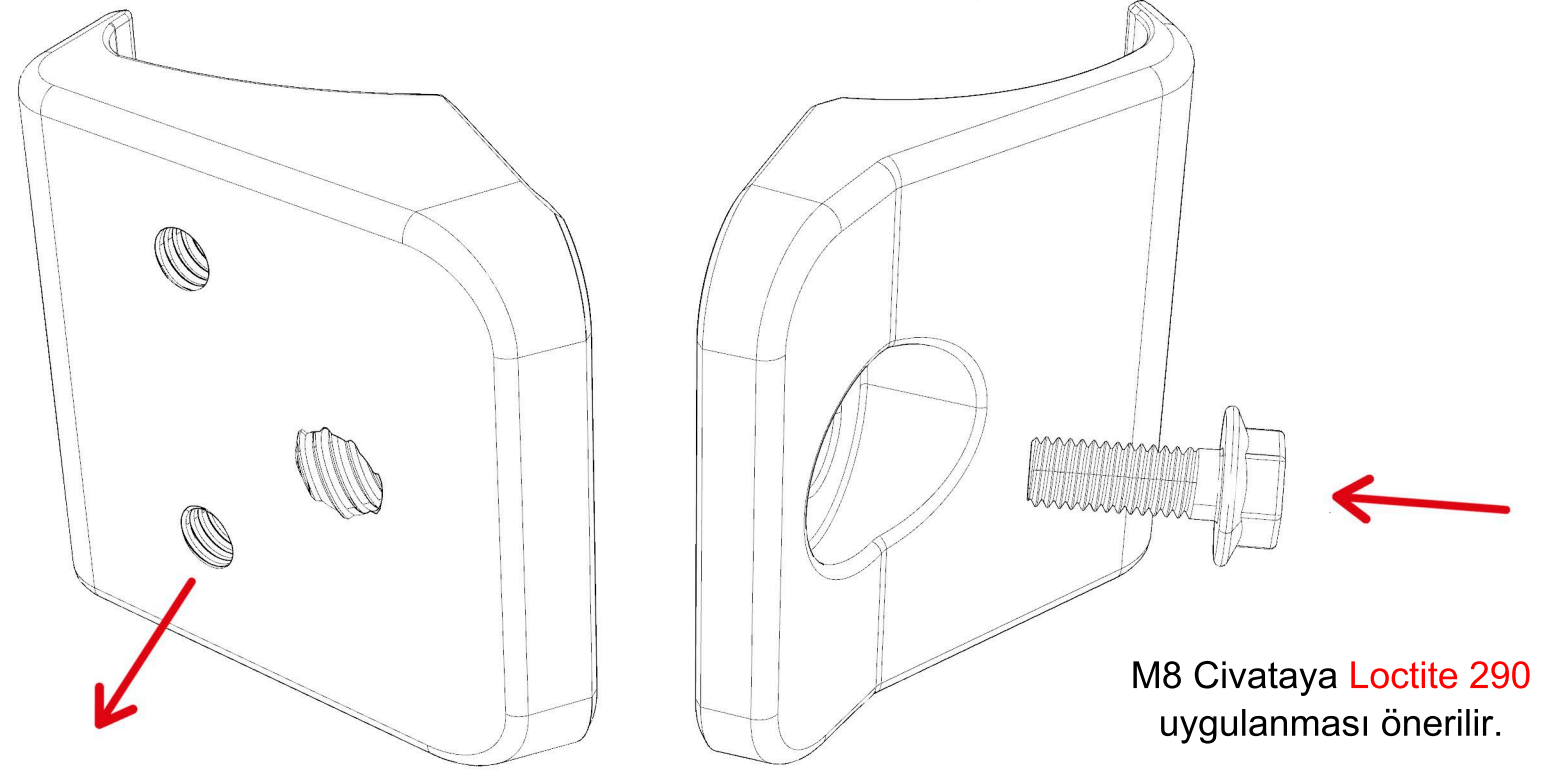

M8×20 mm İmbus Civata
M6×12 mm Altıgen Başlı Civata



M6 Civatalara **Loctite 290**
uygulanması önerilir.

M8 Civataya **Loctite 290**
uygulanması önerilir.

Farklı forklift modellerinde, boru çapına veya aparat konumuna göre alternatif montaj seçenekleri uygulanabilir.

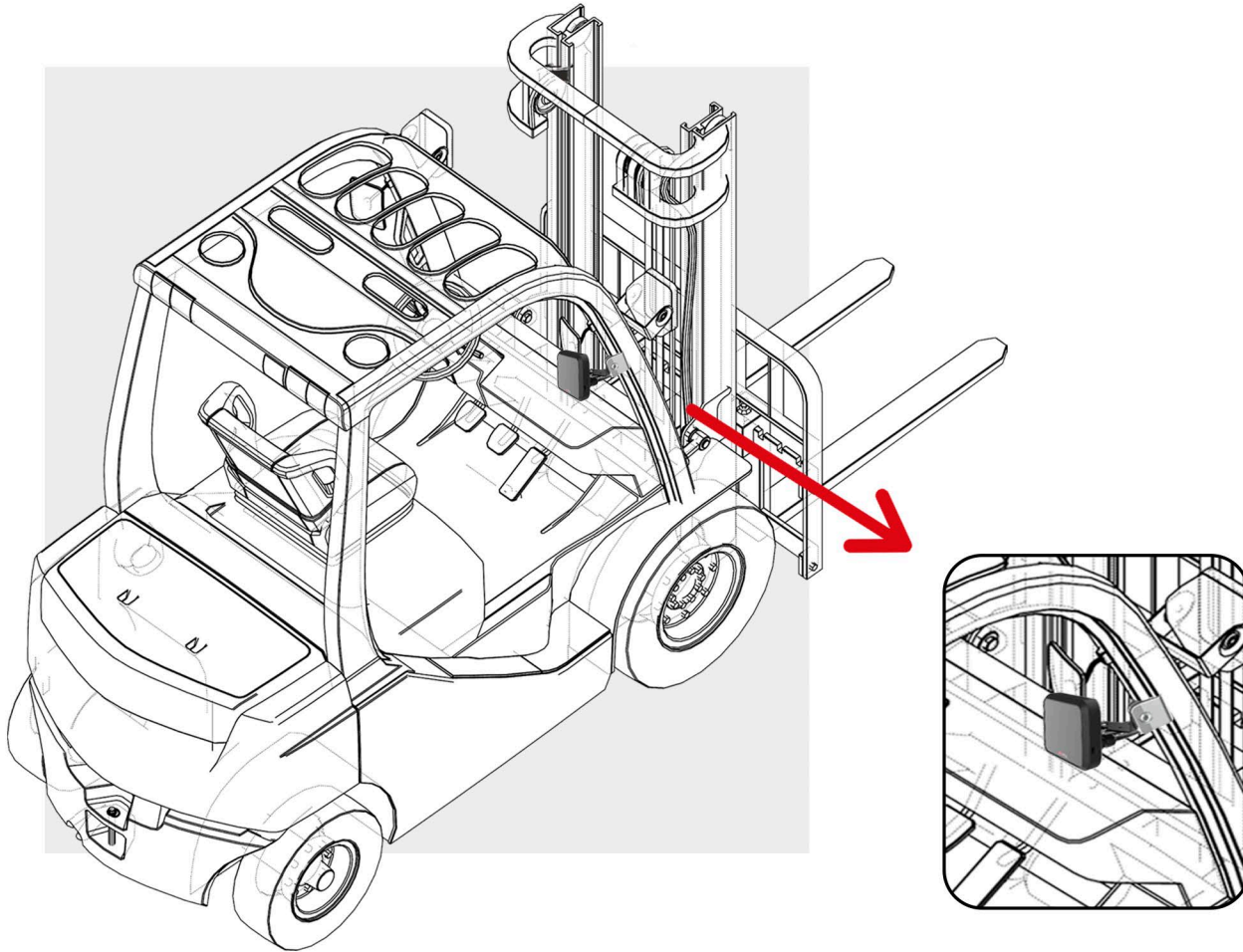

Forkliftin iç kısmında operatörün görüş açısına göre Still FCU Kurt Ağzı, FCU 3.0 Montaj Ayağı ile beraber monte edilir. Montaj sırasında, iki plaka M8×20 mm İmbus Civata ile sabitlenir ve FCU 3.0 Montaj Ayakları ile bağlantı M6×12 mm Altıgen Başlı Civatalar yardımıyla gerçekleştirilir.

Assembly Instructions - FCU Clamping Bracket



M8×20 mm Hex Socket Head Cap Screw
M6×12 mm Hex Head Bolt

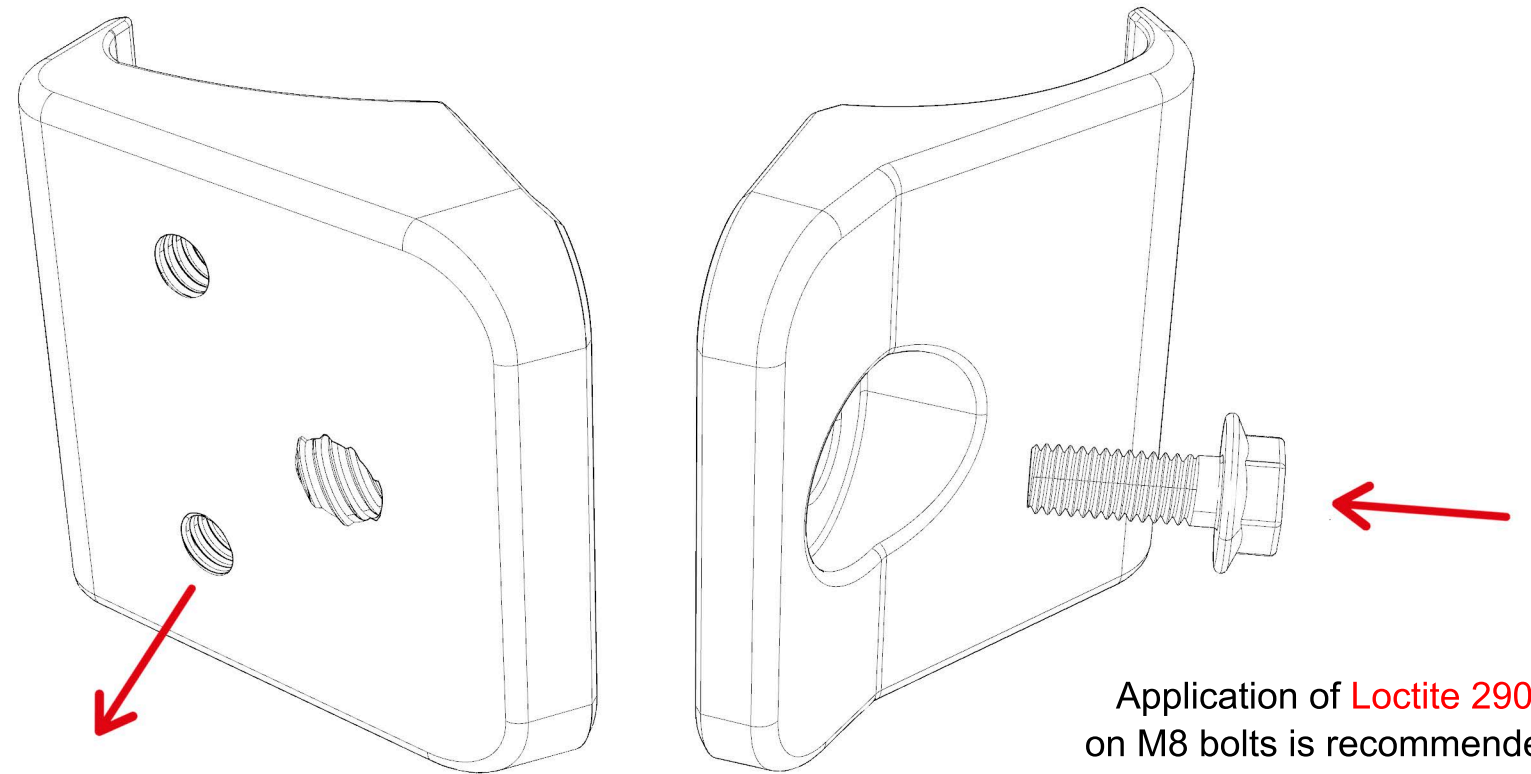

Application of **Loctite 290**
on M6 bolts is recommended.

Application of **Loctite 290**
on M8 bolts is recommended.

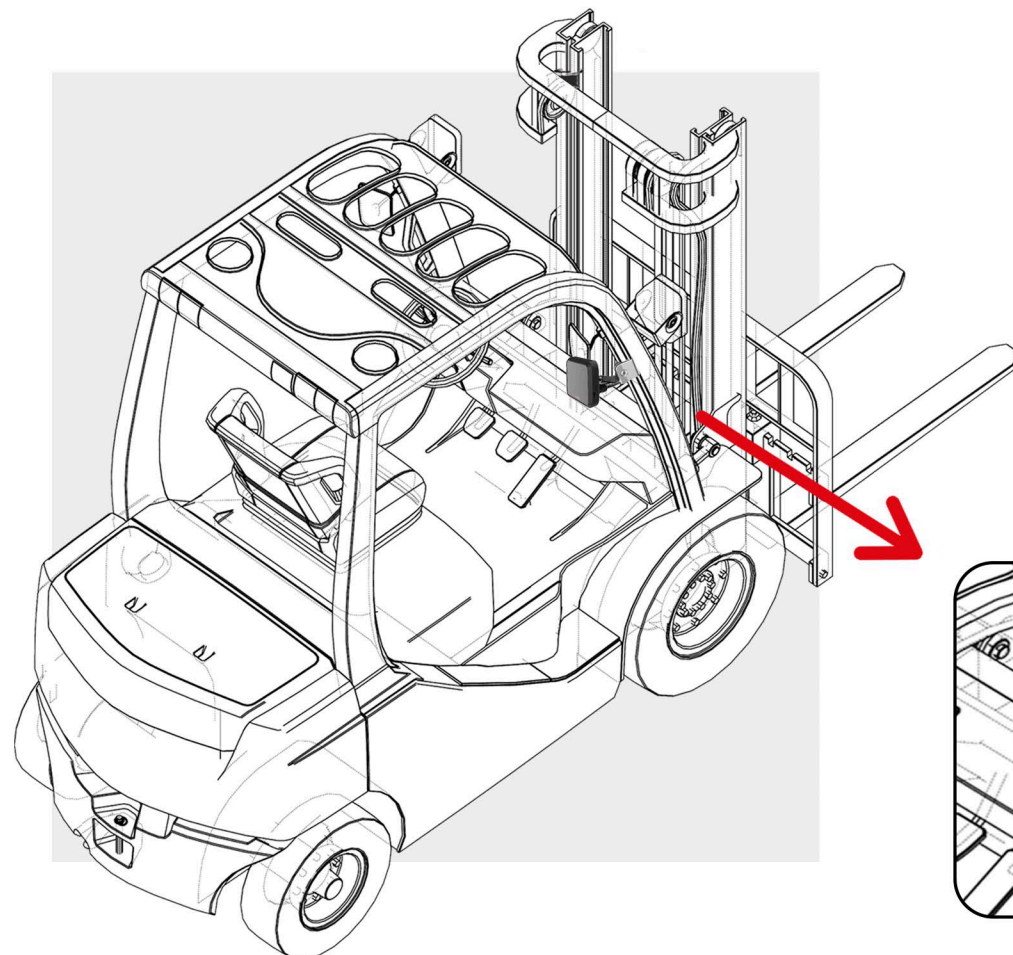

For different forklift models, alternative mounting options can be applied depending on the tube diameter or the position of the bracket.

Inside the forklift, the FCU clamping bracket is mounted together with the FCU 3.0 Mounting Bracket according to the operator's line of sight.

During installation, the two plates are secured with M8×20 mm hex socket head cap screws, and the connection to the FCU 3.0 Mounting Bracket is made using M6×12 mm hex head bolts.