

Montaj Talimatları - İşkence Küçük ve Büyük Ayak

Takoz takılmayan yüzeyine **3M Çift Taraflı Bant** yapıştırılmalıdır.
3M Bantın yapışacağı yüzey, uygulama öncesinde alkol ile temizlenmeli ve tamamen kuruması beklenmelidir.

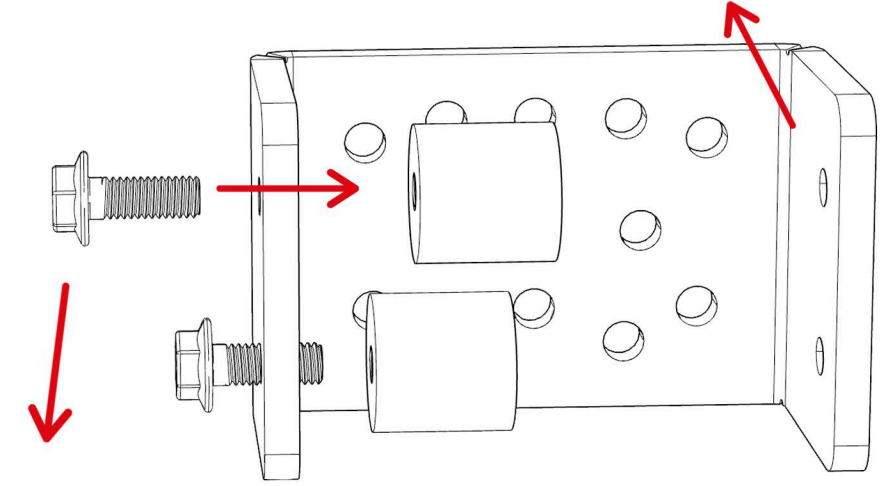

M6 Civatalara **Loctite 290** uygulanması önerilir.

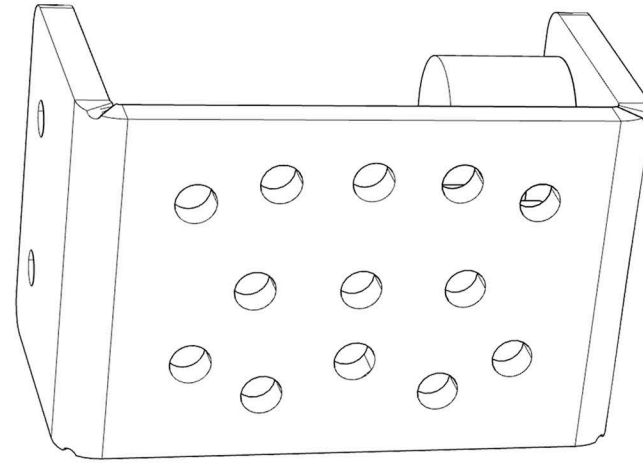
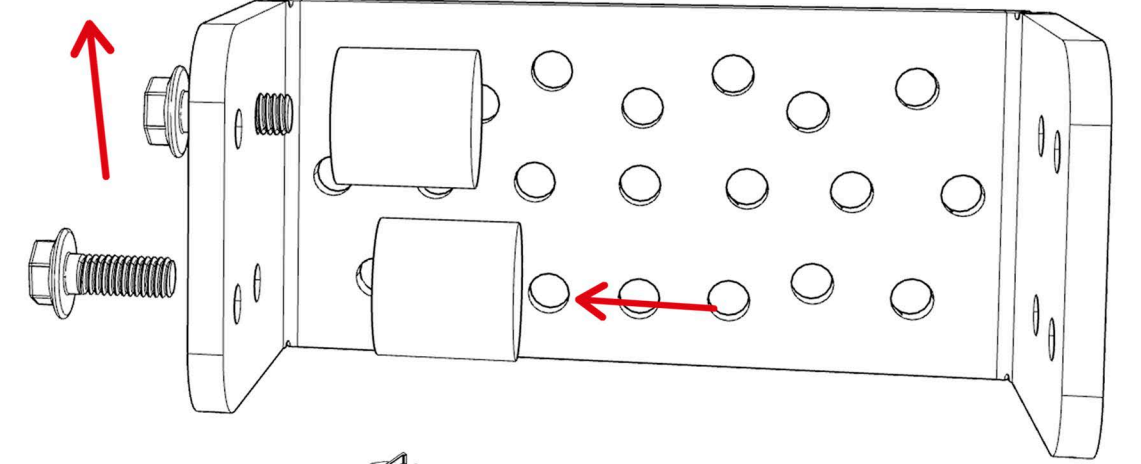
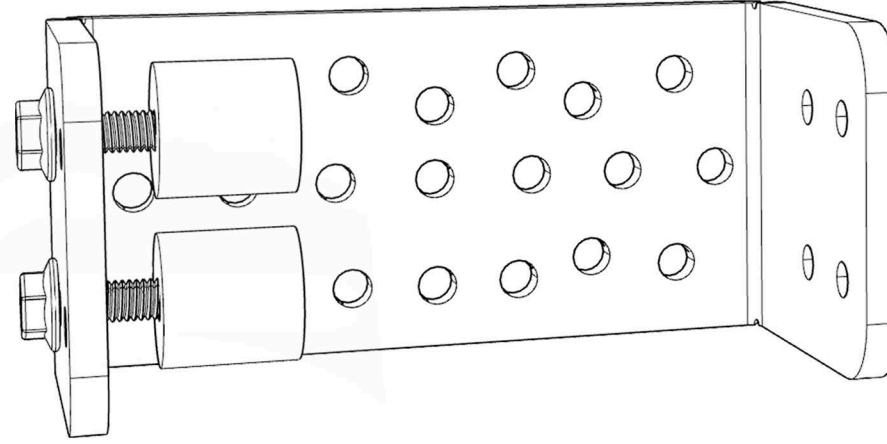

M6×30-35 mm Altıgen Başlı Civata
VHB110GPH 3M Çift Taraflı Bant
20×20 mm Titreşim Takozu

Montaj sırasında, seçilen ayak arasına titreşim takozları yerleştirilir ve M6 × 30 mm ya da M6 × 35 mm civata ile sıkıştırılır.

Loctite uygulanmadan montaj yapılmamalıdır.
Gerekli durumlarda vida boyu sahada belirlenebilir.
Civatalar sıkılırken takozun düzgün hizalandığından emin olunmalıdır.
3M Bant uygulanmadan önce yüzeyin yağ, toz ve kirden tamamen arındırılması gerekir.

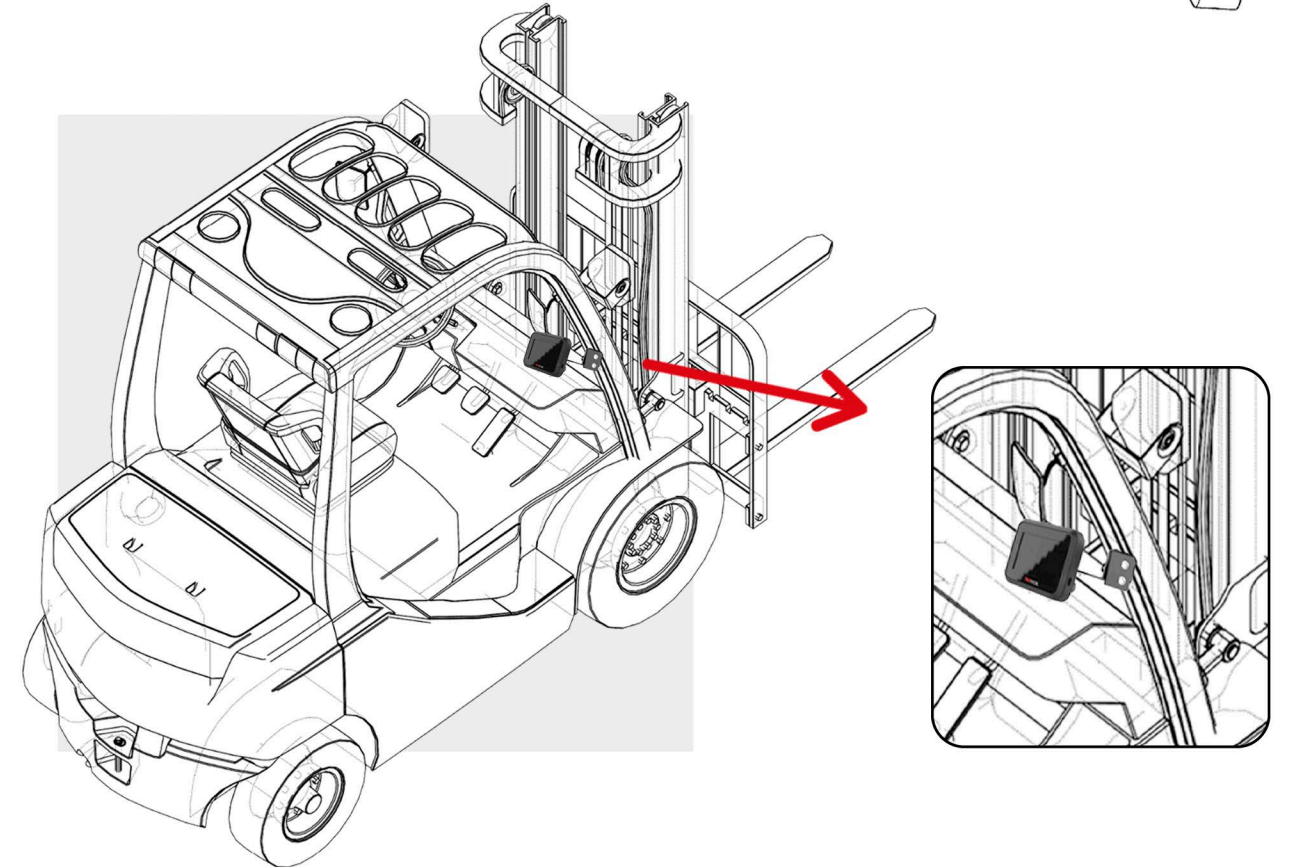

Assembly Instructions - Large & Small Clamping Bracket

Apply 3M double-sided tape to the surface where the block is not attached. The surface intended for the 3M tape must be cleaned with alcohol before application and allowed to dry completely.

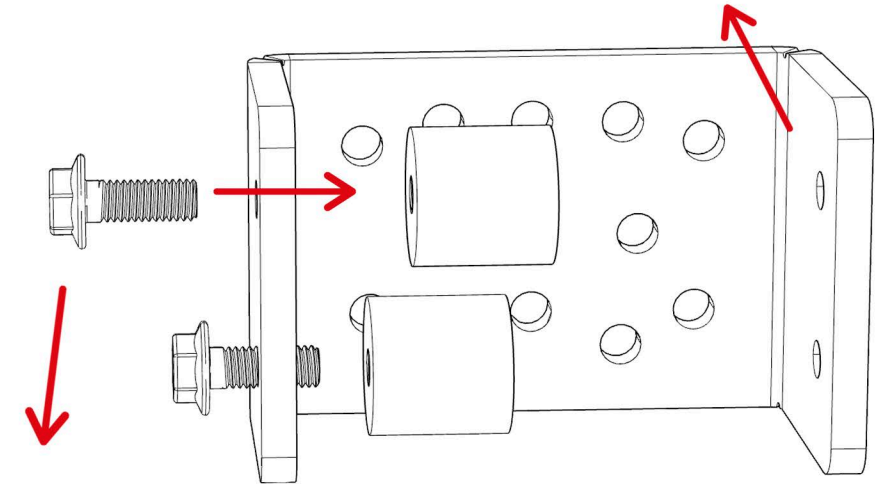
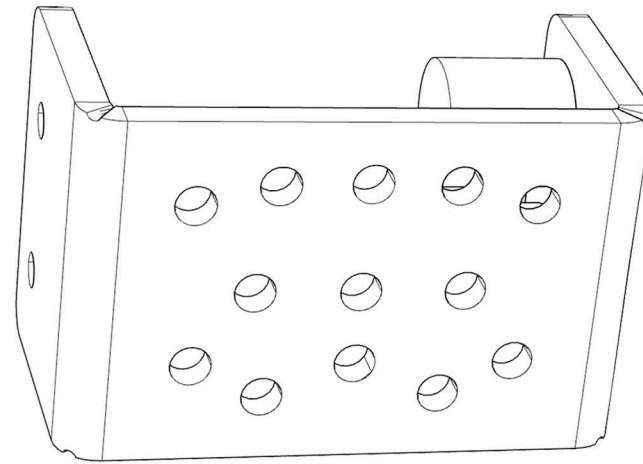

Application of **Loctite 290** on M6 bolts is recommended.

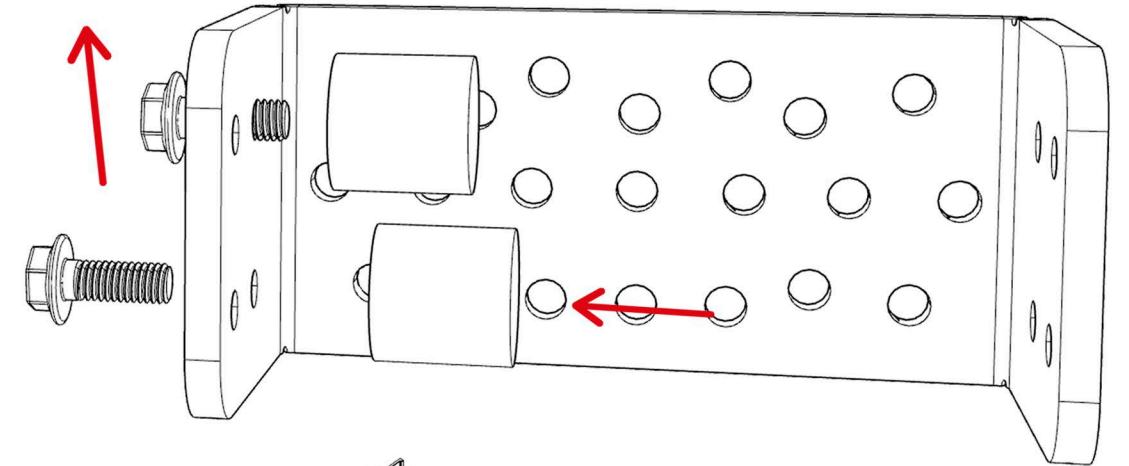
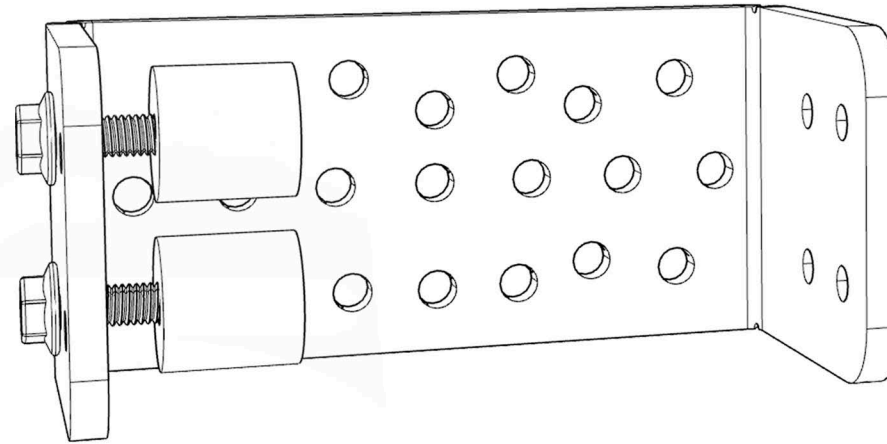

M6×30–35 mm Hex Head Bolt
3M VHB110GPH Double-Sided Tape
20×20 mm Vibration Pad

During installation, vibration pads are placed between the selected foot and secured with M6 × 30 mm or M6 × 35 mm bolts.

Installation should not be performed without applying Loctite.
If necessary, the bolt length can be determined on site.
Ensure the vibration pad is properly aligned when tightening the bolts.
Before applying the 3M tape, the surface must be completely free of oil, dust, and dirt.

